



## Installation Instructions for 95-7624

### APPLICATIONS

# Nissan Multi-kit 2007-up

(see application list on page 2)

## 95-7624



### KIT FEATURES

- Double DIN radio provision

### KIT COMPONENTS

- A) Radio housing trim panel, standard
- B) Radio housing trim panel, wide
- C) Bracket #1
- D) Bracket #2
- E) Bracket #3
- F) Spacers

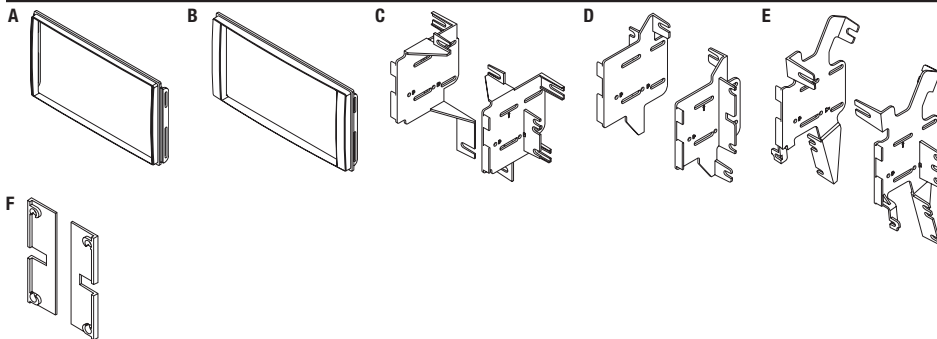

### WIRING & ANTENNA CONNECTIONS (sold separately)

Wiring Harness: • 70-7552 - Nissan 2007-up

Antenna Adapter: • 40-NI12 - Nissan 2007-up

### TOOLS REQUIRED

- Panel removal tool
- Phillips screwdriver

**CAUTION:** Metra recommends disconnecting the negative battery terminal before beginning any installation. All accessories, switches, and especially air bag indicator lights must be plugged in before reconnecting the battery or cycling the ignition.

**NOTE:** Refer to the instructions included with the aftermarket radio.

## Applications

### Chevrolet

City Express	2015-up
--------------	---------

### Nissan

Cube	2009-up
Frontier (with 4.3" screen)	2013-up
Juke	2011-up
NV	2012-up
NV200	2013-up
Quest (without NAV or rear seat entertainment)	2011-up
Rogue	2011-up
Rogue Select	2014
Titan (with 4.3" screen)	2013-up
Versa	2007-up
Versa Note	2014-up
Xterra (with 4.3" screen)	2013-up

## Table of Contents

### Dash Disassembly

– Cube 2009-up.....	3
– Frontier/Xterra (with 4.3" screen) 2013-up.....	3
– Juke 2011-up.....	4
– NV 2012-up.....	5
– NV200 2013-up, Chevrolet City Express 2015-up.....	6
– Quest (without NAV or rear seat entertainment) 2011-up.....	7-8
– Rogue 2011-2013.....	9
– Rogue Select 2014.....	9
– Titan (with 4.3" screen) 2013-up.....	10
– Versa 2007-2011.....	10
– Versa 2012-up.....	11
– Versa Note 2014-up.....	11

### Kit Assembly

– Radio housing trim panel usage.....	12
– Bracket tab layouts.....	13-15
– Double DIN radio provision.....	16

### Nissan Cube 2009-up

1. Remove (2) Phillips screws from the bottom of the a/c trim panel then unclip and remove the panel. (Figure A,B)
2. Remove (2) Phillips screws from the bottom of the radio trim panel then unclip and remove the panel. (Figure C)
3. Remove (4) Phillips screws securing radio to dash to remove.

*Continue to kit assembly*

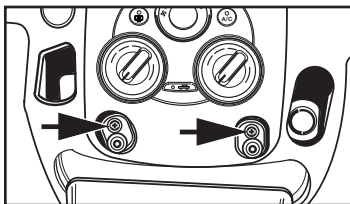

(Figure A)

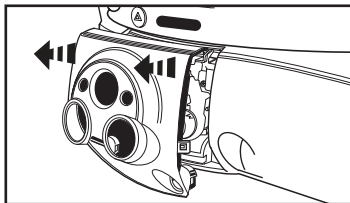

(Figure B)

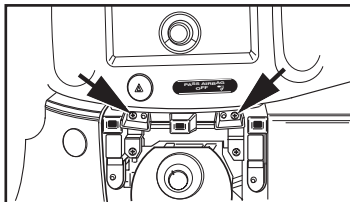

(Figure C)

### Nissan Frontier/Xterra (with 4.3" screen) 2013-up

1. Unclip and remove the trim panel above the radio and climate controls. (Figure A)
2. Remove the (1) Phillips screw under panel and the (2) Phillips screws securing the radio brackets to the sub dash. (Figure B)
3. Unclip and remove the entire panel including the climate controls and factory radio.
4. Remove (4) Torx screws securing the radio to the trim panel. (Figure C, D)

*Continue to kit assembly*

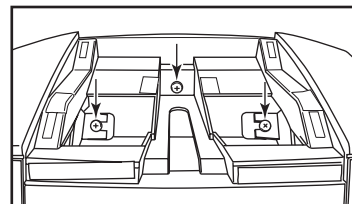

(Figure B)

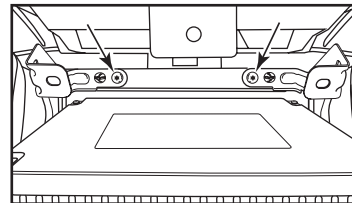

(Figure C)

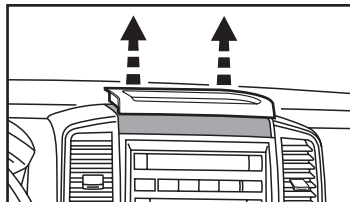

(Figure A)

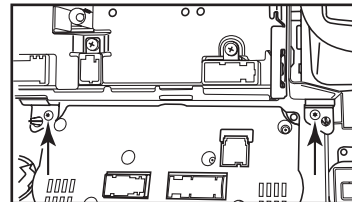

(Figure D)

**Nissan Juke 2011-up**

1. Unclip and remove the climate control panel. (Figure A)
2. Remove (2) Phillips screws securing the radio trim panel. (Figure B)
3. Remove (4) Phillips screws securing radio, unplug and remove radio. (Figure C)

*Continue to kit assembly*

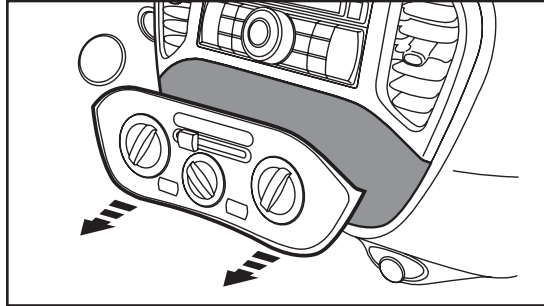

(Figure A)

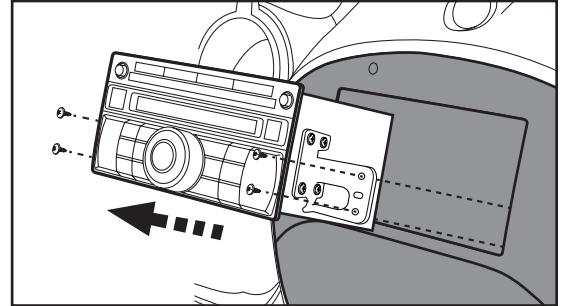

(Figure C)

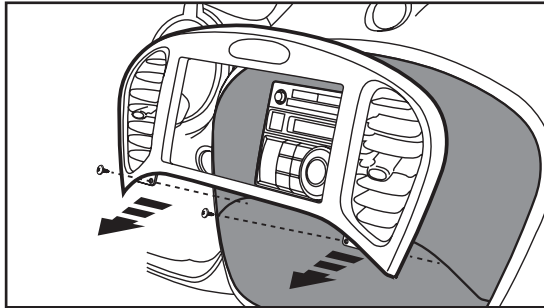

(Figure B)

### Nissan NV 2012-up

1. Unclip and remove the A/C vent to the right side of the factory radio. (Figure A)
2. Remove the (2) Phillips screws exposed behind vent on radio trim panel. (Figure B)
3. Unclip and remove the left A/C vent next to the instrument display. (Figure C)
4. Unclip the top edge of the knee bolster panel below the steering column and let hang. (Figure D)

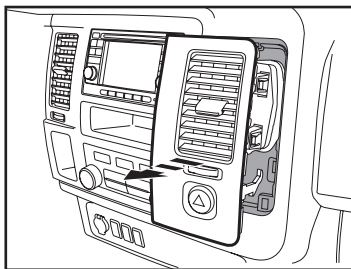

(Figure A)

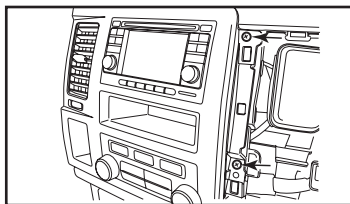

(Figure B)

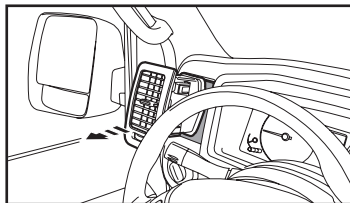

(Figure C)

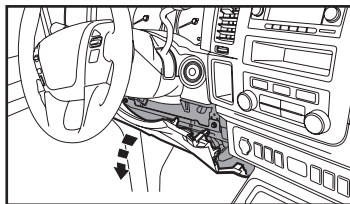

(Figure D)

5. Unclip the circle trim around the key cylinder. (Figure E)
6. Unclip and remove the gauge cluster trim panel. (Figure F)
7. Remove (2) Phillips screws exposed behind the panel on the left side of the radio trim panel. (Figure F)
8. Unclip and remove the trim panel surrounding the factory radio. (Figure G)
9. Remove (4) Phillips screws securing the radio. (Figure H)

*Continue to kit assembly*

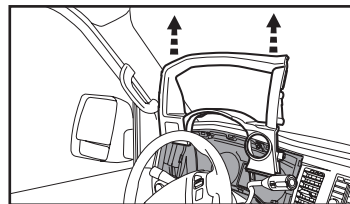

(Figure E)

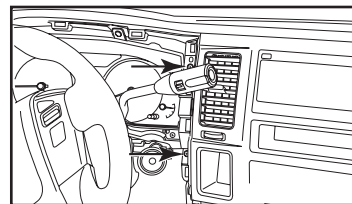

(Figure F)

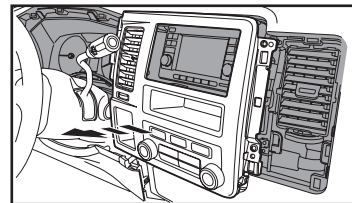

(Figure G)

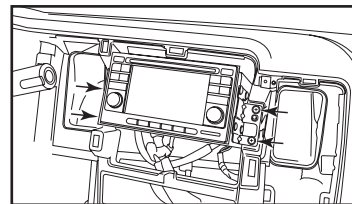

(Figure H)

**Chevrolet City Express 2015-up, Nissan NV200 2013-up**

1. Unclip and remove the recirculate/fresh slide button. (Figure A)
2. Unclip and remove the entire panel surrounding the radio including the a/c vents. (Figure B)
3. Remove (4) Phillips screws securing the radio. (Figure C)

*Continue to kit assembly*

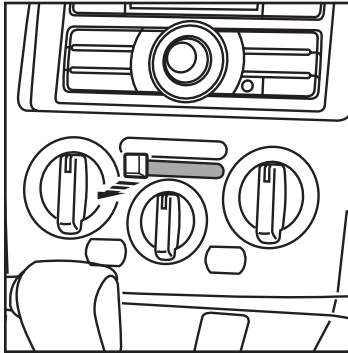

(Figure A)

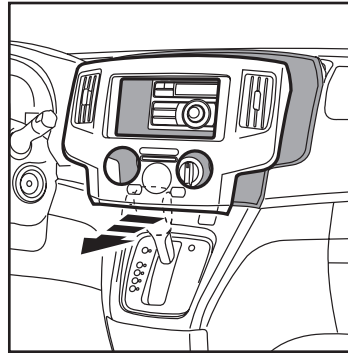

(Figure B)

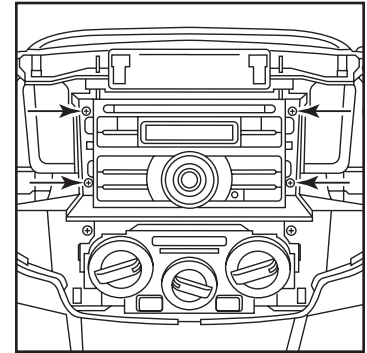

(Figure C)

### Nissan Quest (without NAV or rear seat entertainment) 2011-up

1. Unclip and remove the panels from the bottom left and right side of the center console. (Figure A)

2. Remove (2) clips per side exposed behind lower panels. (Figure B)

3. Unclip and pull center console toward rear of vehicle.

**Note: You do not have to fully remove console.** (Figure C)

4. Unclip and remove the trim panel to the left of the shifter housing the start/stop button. (Figure D)

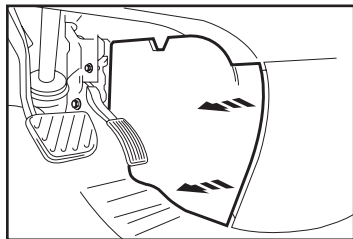

(Figure A)

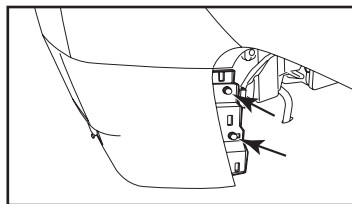

(Figure B)

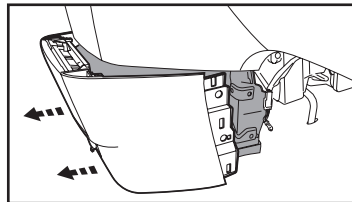

(Figure C)

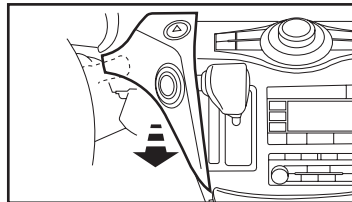

(Figure D)

5. Unclip and remove the panel on the end of the passenger side of the dash. (Figure E)

6. Remove (1) Phillips screw from the trim panel above the glove box then unclip and remove the panel. (Figure F)

*Continued on next page*

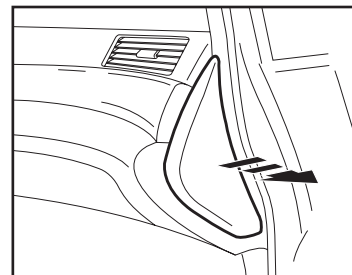

(Figure E)

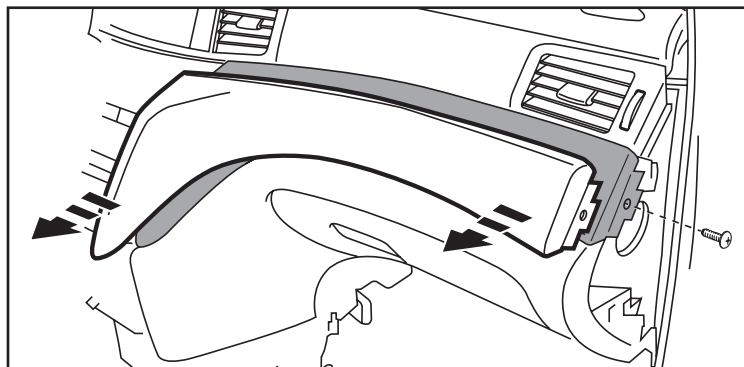

(Figure F)

**Nissan Quest (without NAV or rear seat entertainment) 2011-up**

7. Remove (1) Phillips screw from the cup holder panel then unclip and remove the panel. (Figure G)

8. Remove (2) Phillips screws from the a/c control panel and unclip and let hang. (Figure H)

9. Remove (2) Phillips screws from the bottom of the radio trim panel including the vents then unclip and remove the panel. (Figure H)

10. Remove (4) Phillips screws securing the radio. (Figure I)

*Continue to Kit Assembly*

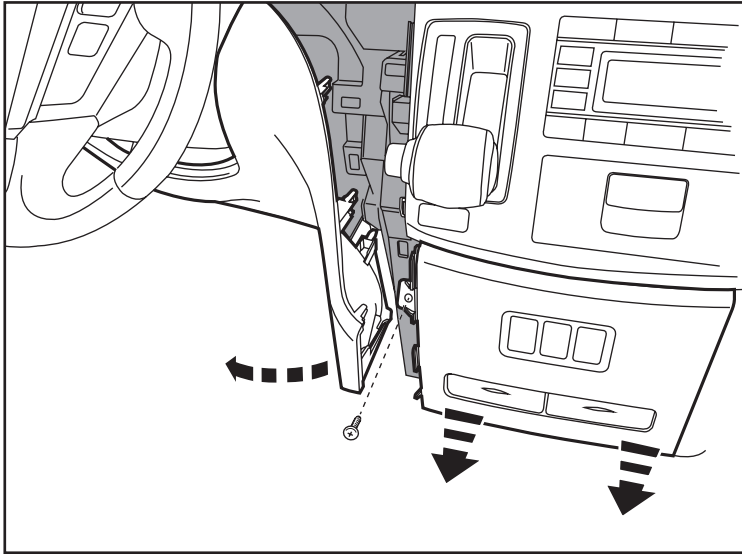

(Figure G)

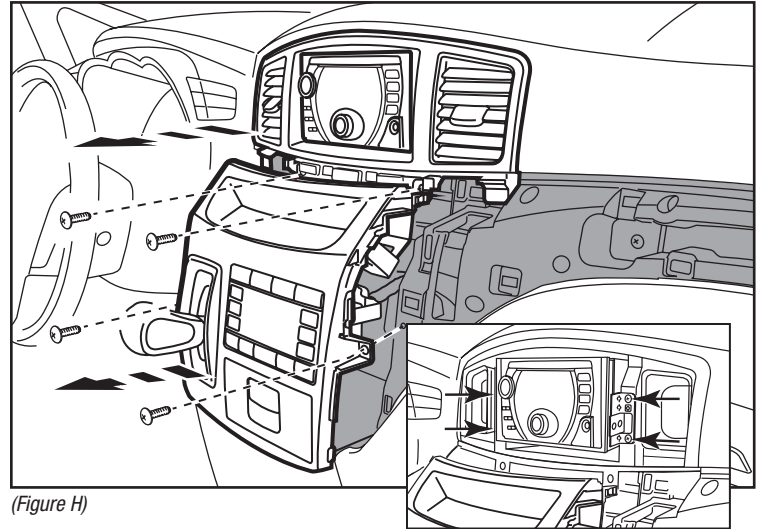

(Figure H)

(Figure I)



### Rogue 2011-2013, Rogue Select 2014

- 1. If equipped with center speaker:** Unclip and remove the grille then remove (4) Phillips screws to remove the speaker. (Figure A)
- 2.** Unclip and remove the panel below the radio including the a/c controls. (Figure B)
- 3.** Unclip the radio trim including the a/c vents then unplug the hazard switch and remove the panel. (Figure C)
- 4.** Remove (4) Phillips screws securing the radio. (Figure D)  
*Continue to kit assembly*

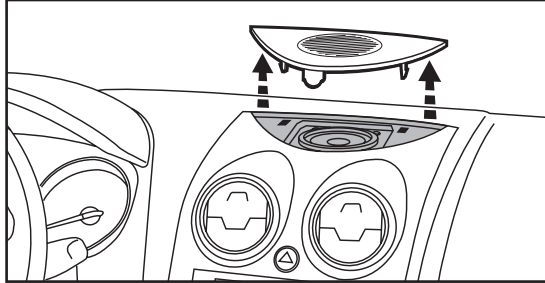

(Figure A)

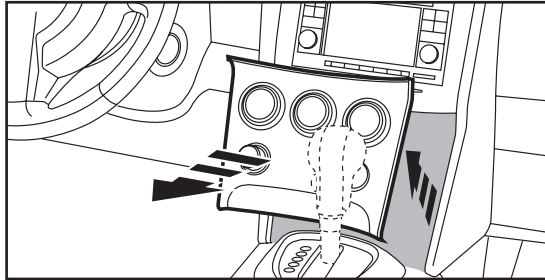

(Figure B)

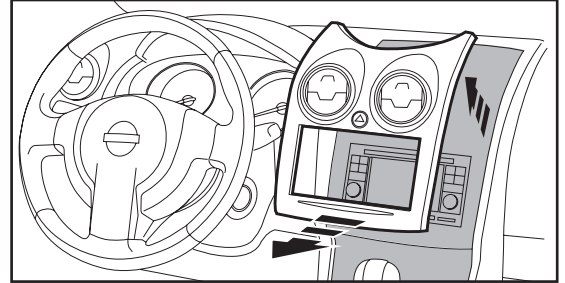

(Figure C)

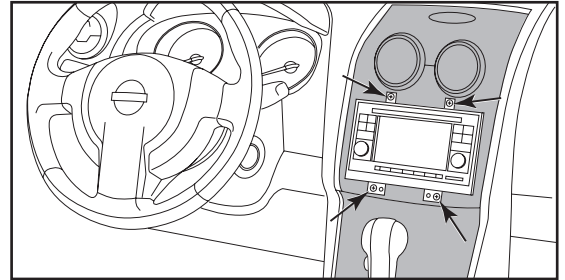

(Figure D)

### Nissan Titan (with 4.3" screen) 2013-up

1. Unclip the entire dash panel including the climate controls. Unplug and remove the panel. (Figure A)
2. Remove (4) Phillips screws securing the radio. Unplug and remove the chassis. (Figure B)

*Continue to kit assembly*

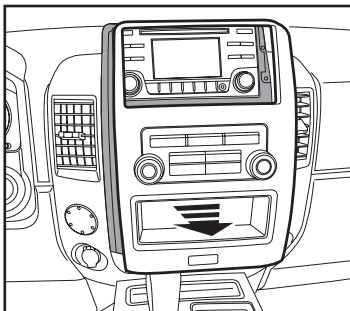

(Figure A)

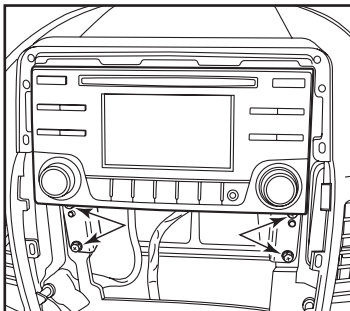

(Figure B)

### Nissan Versa 2007-2011

1. Unclip and remove the panel above the radio. (Figure A, B)
2. Remove (2) Phillips screws securing the radio trim panel then unclip and remove the entire panel surrounding the radio and A/C controls. (Figure C)
3. Remove (4) Phillips screws securing radio, unplug and remove radio. (Figure D)

*Continue to kit assembly*

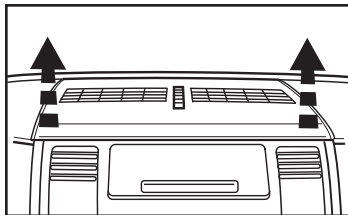

(Figure A)

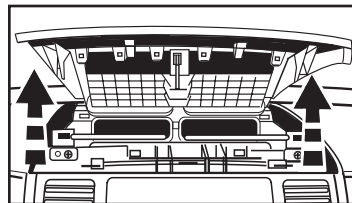

(Figure B)

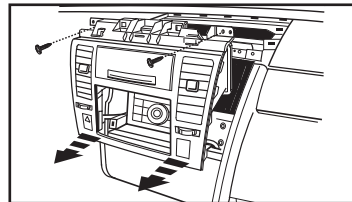

(Figure C)

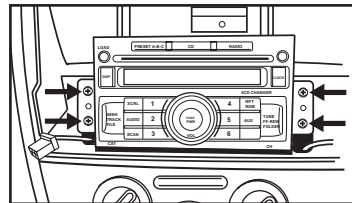

(Figure D)

**Versa 2012-up, Versa Note 2014-up**

1. Unclip and remove the entire panel surrounding the radio including the A/C vents. (Figure A)
2. Remove (4) Phillips screws securing the radio. (Figure B)

*Continue to kit assembly*

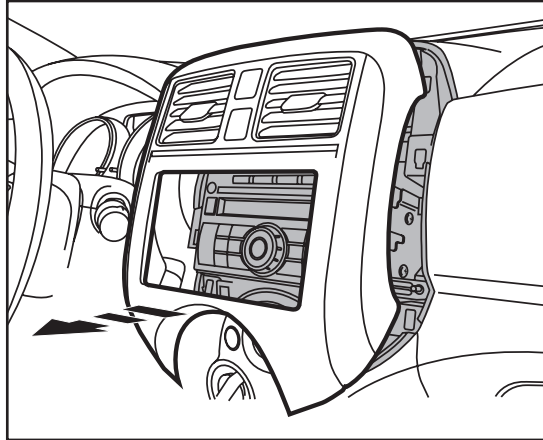

(Figure A)

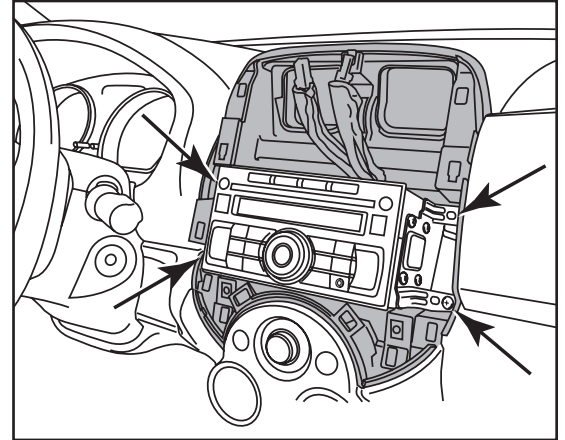

(Figure B)



## 95-7624 Kit Assembly

### Radio housing trim panel usage

Vehicle	Trim panel
Cube 2009-up	Standard
Frontier (with 4.3" screen) 2013-up	Wide
Juke 2011-2014	Standard
Juke 2015-up	Wide
NV 2012-up	Standard
NV200 2013-up, Chevrolet City Express 2015-up (both without NAV)	Standard
NV200 2013-up, Chevrolet City Express 2015-up (both with NAV)	Wide
Quest (without NAV or rear seat entertainment) 2011-2012	Standard
Quest (without NAV or rear seat entertainment) 2013-up	Wide
Rogue Select (with lower model radio) 2014	Standard
Rogue Select (with upper model radio) 2014	Wide
Rogue S (with Special Edition Package) 2012-2013	Wide
Rogue SV 2012-2013	Wide
Rogue S and SV (with SL Package) 2003-2007	Standard
Rogue 2011	Standard
Titan (with 4.3" screen) 2013-up	Wide
Versa 2007-2011	Standard
Versa 2012-2013	Standard
Versa S, S+ and SV (without options) 2014	Standard
Versa Note 2014	Wide
Versa SL and SV (with Convenience Package) 2014	Wide
Versa and Versa Note (all models) 2015-up	Wide
Xterra (with 4.3" screen) 2013-up	Wide

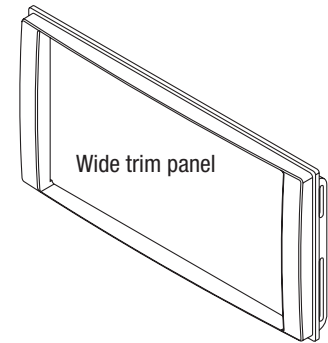
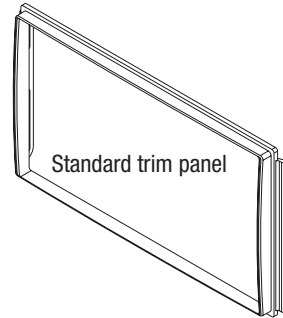

### Bracket #1 tab layout

Bracket #	Tab	Vehicle
1	A	Versa 2012-up
1	A	Versa Note 2014-up
1	B	Rogue 2011-2013
1	B	Rogue Select 2014
1	C	NV 2012-up
1	C	Quest (without NAV or rear seat entertainment) 2011-up

**Note:** It may be necessary to remove all unneeded tabs from the brackets for certain applications. Depending on the application it may also be necessary to trim the entire bracket as close as possible to the radio mounting locations on the brackets.

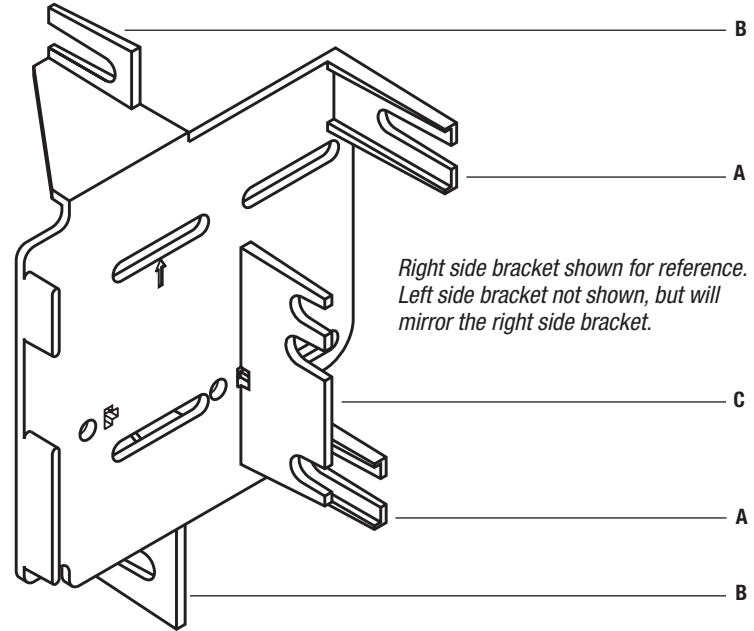



## 95-7624 Kit Assembly

### Bracket #2 tab layout

Bracket #	Tab	Vehicle
2	E	Chevrolet City Express 2015-up
2	D	Nissan Juke 2011-up
2	E	Nissan NV200 2013-up
2	E	Nissan Cube (use spacers) 2009-up

**Note:** It may be necessary to remove all unneeded tabs from the brackets for certain applications. Depending on the application it may also be necessary to trim the entire bracket as close as possible to the radio mounting locations on the brackets.

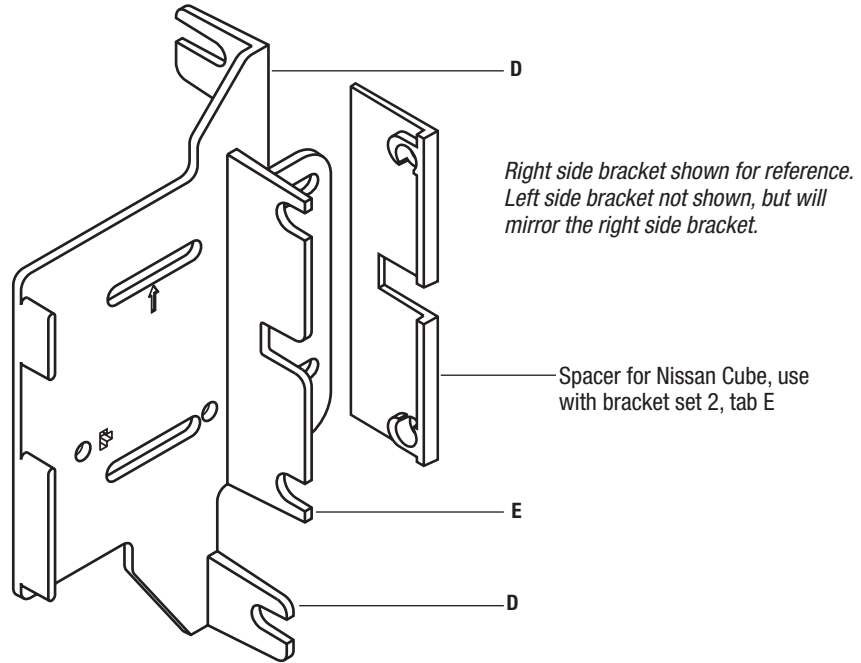

## Bracket #3 tab layout

Bracket #	Tab	Vehicle
3	F	Frontier/Xterra (with 4.3" screen) 2013-up
3	G	Titan 2013-up
3	H	Versa 2007-2011

**Note:** It may be necessary to remove all unneeded tabs from the brackets for certain applications. Depending on the application it may also be necessary to trim the entire bracket as close as possible to the radio mounting locations on the brackets.

1. Cut and remove the shaded area of the brackets for the 2013-up Frontier and Xterra. (Figure A)
2. Cut and remove the shaded area of the brackets for the 2013-up Titan. (Figure A)

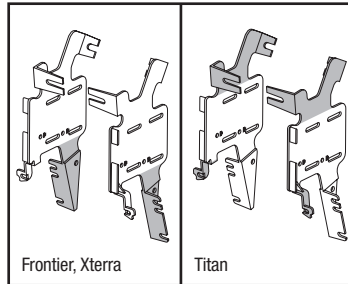

(Figure A)

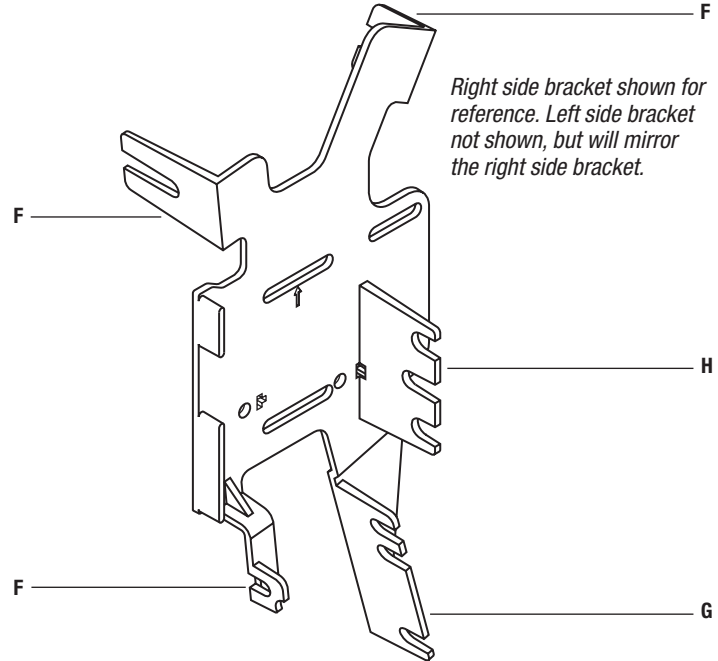

### Kit Assembly

#### Double DIN radio provision

1. Attach your corresponding bracket to the radio housing trim panel. *(Bracket #2 with the standard radio trim panel shown) (Figure A)*
2. Slide the radio into the assembly and secure with screws supplied with the radio. (Figure B)
3. Locate the factory wiring harness and antenna plug in the dash. Metra recommends using the proper mating adapters from Metra and/or AXCESS.
4. Mount the new radio assembly into the dash and reassemble dash in reverse order of disassembly.

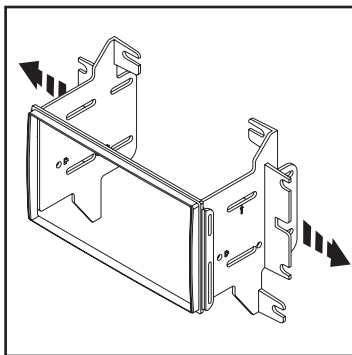

(Figure A)

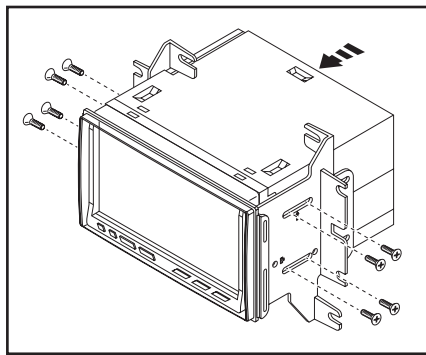

(Figure B)





**95-7624**

---

---

---

---

---

---

---

---

---

---

---

---

---

---

---

---

---

---

---

---

---

---

---

---

---

---

---

---

---

---

---

---





95-7624

A large central area of the page is filled with horizontal lines, organized into two columns. Each column contains 14 lines, providing a space for handwritten notes or calculations.



## Installation Instructions for 95-7624



REV. 1/9/2015 INST95-7624



### KNOWLEDGE IS POWER

Enhance your installation and fabrication skills by enrolling in the most recognized and respected mobile electronics school in our industry. Log onto [www.installerinstitute.com](http://www.installerinstitute.com) or call 800-354-6782 for more information and take steps toward a better tomorrow.



**Metra recommends MECP  
certified technicians**



## INSTRUCCIONES DE INSTALACIÓN PARA LA PIEZA 95-7624

### APLICACIONES

## Nissan multi-kit 2007 y mas

(ver la lista de aplicaciones de la página 2)

## 95-7624



### CARACTERÍSTICAS DEL KIT

- Provisión de radio doble DIN

### COMPONENTES DEL KIT

- A) Panel de moldura para la carcasa del radio, estándar • B) Panel de moldura para la carcasa del radio, ancho
- C) Soporte #1 • D) Soporte #2 • E) Soporte #3 • F) Espaciadores

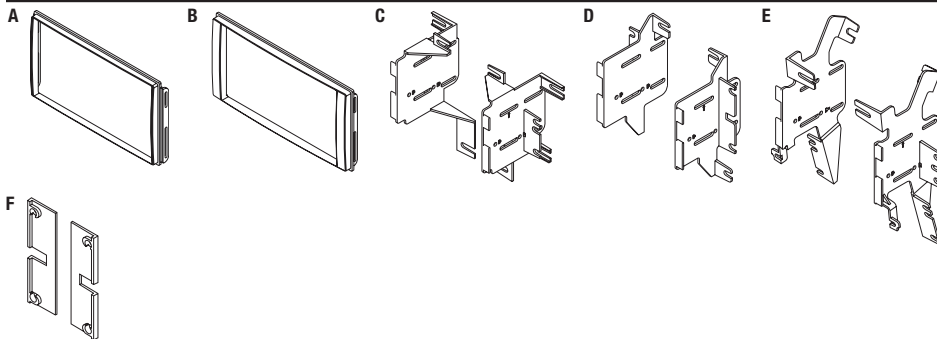

### CABLEADO Y CONEXIONES DE ANTENA

(se venden por separado)

Arnés de cables: • 70-7552 – Nissan 2007 y más recientes

Adaptador de antena: • 40-NI12 – Nissan 2007 y más recientes

### HERRAMIENTAS REQUERIDAS

- Herramienta para quitar paneles
- Destornillador Phillips

**PRECAUCIÓN:** Metra recomienda desconectar el terminal negativo de la batería antes de comenzar cualquier instalación. Todos los accesorios, interruptores y, especialmente, las luces indicadoras de airbag deben estar enchufados antes de volver a conectar la batería o comenzar el ciclo de ignición.

**Nota:** Remítase a las instrucciones incluidas con el radio de posventa.

## Aplicaciones

### Chevrolet

City Express	2015 y mas
--------------	------------

### Nissan

Cube	2009 y mas
Frontier (con pantalla de 4.3")	2013 y mas
Juke	2011 y mas
NV	2012 y mas
NV200	2013 y mas
Quest (sin NAV o entretenimiento para el asiento trasero)	2011 y mas
Rogue	2011 y mas
Rogue Select	2014
Titan (con pantalla de 4.3")	2013 y mas
Versa	2007 y mas
Versa Note	2014 y mas
Xterra (con pantalla de 4.3")	2013 y mas

## Indice

### Desmontaje del tablero

– Cube 2009 y mas	3
– Frontier/Xterra (con pantalla de 4.3") 2013 y mas	3
– Juke 2011 y mas	4
– NV 2012 y mas	5
– NV 200 2013 y mas	6
– Quest (sin NAV o entretenimiento para el asiento trasero) 2011 y mas	7-8
– Rogue 2011-2013	9
– Rogue Select 2014	9
– Titan (con pantalla de 4.3") 2013 y mas	10
– Versa 2007-2011	10
– Versa 2012 y mas	11
– Versa Note 2014 y mas	11

### Ensamble del kit

– Aplicaciones de la placa de la moldura	12
– Diseños de la ficha Soporte	13-15
– Provisión de radio doble DIN	16

**Nissan Cube 2009 y mas**

1. Quite los (2) tornillos Phillips de la parte inferior del panel de la moldura del aire acondicionado y luego desenganche y retire el panel. (Figura A,B)
2. Quite los (2) tornillos Phillips de la parte inferior del panel de la moldura del radio y luego desenganche y retire el panel. (Figura C)
3. Quite los (4) tornillos Phillips que sujetan el radio al tablero y retire.

*Continúe con el ensamble del kit*

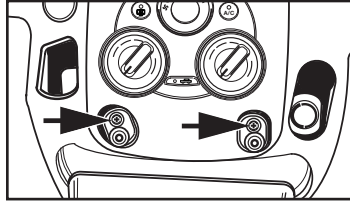

(Figura A)

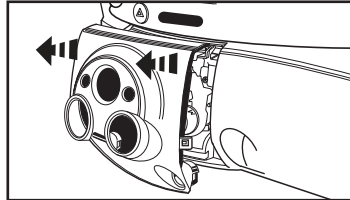

(Figura B)

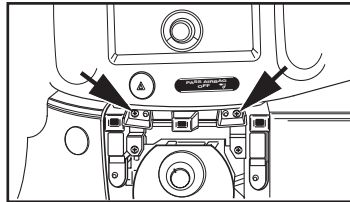

(Figura C)

**Nissan Frontier/Xterra (con pantalla de 4.3") 2013 y mas**

1. Desenganche y quite el panel de moldura de arriba del radio y los controles del clima. (Figura A)
2. Quite el tornillo Phillips (1) de debajo del panel y los (2) tornillos Phillips que sujetan los soportes del radio al sub tablero. (Figura B)
3. Desenganche y quite todo el panel, incluyendo los controles del clima y el radio de fábrica.
4. Quite los (4) tornillos Torx que sujetan el radio al panel de la moldura. (Figura C, D)

*Continúe con el ensamble del kit*

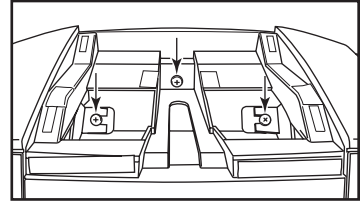

(Figura B)

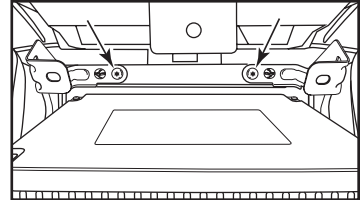

(Figura C)

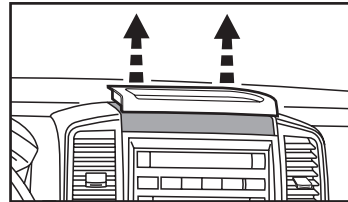

(Figura A)

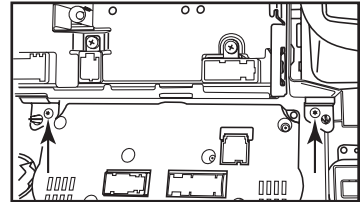

(Figura D)

**Nissan Juke 2011 y mas**

1. Desenganche y quite el panel del control del clima. (Figura A)
2. Quite los (2) tornillos Phillips que sujetan el panel de la moldura del radio. (Figura B)
3. Quite los (4) tornillos Phillips que sostienen el radio, desconecte y quite el radio. (Figura C)

*Continúe con el ensamble del kit*

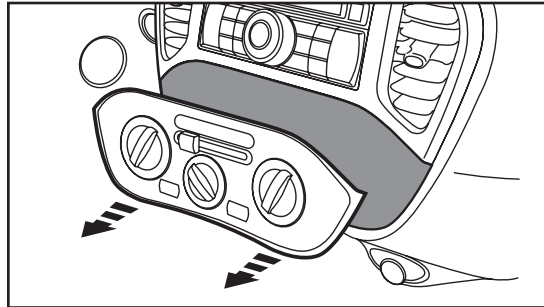

(Figura A)

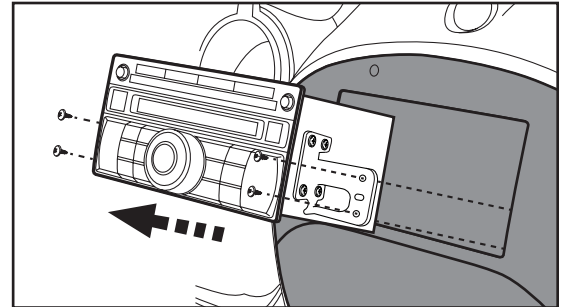

(Figura C)

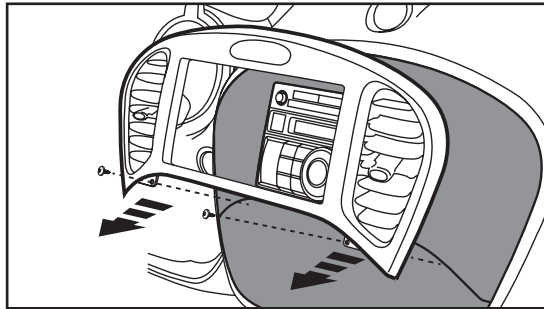

(Figura B)



**Nissan NV 2012 y mas**

1. Desenganche y quite la rejilla del aire acondicionado que está a la derecha del radio de fábrica. (Figura A)
2. Quite los (2) tornillos Phillips que quedan a la vista detrás de la rejilla en el panel de moldura del radio. (Figura B)
3. Desenganche y quite le rejilla del aire acondicionado que está a la izquierda de la pantalla de instrumentos. (Figura C)
4. Desenganche el borde de arriba del panel del refuerzo para rodillas de abajo de la columna de dirección y déjelo colgando. (Figura D)

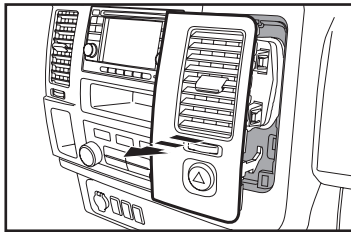

(Figura A)

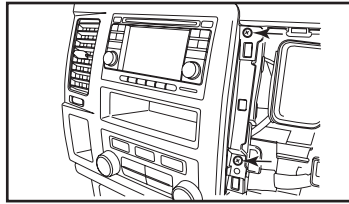

(Figura B)

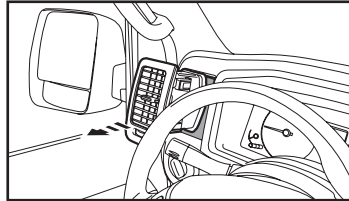

(Figura C)

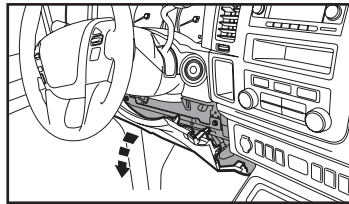

(Figura D)

5. Desenganche la moldura circular alrededor del cilindro de la llave.
6. Desenganche y quite el panel de la moldura del conjunto de indicadores. (Figura E)
7. Quite los (2) tornillos Phillips que quedan a la vista atrás del panel del lado izquierdo del panel de la moldura del radio. (Figura F)
8. Desenganche y retire el panel de moldura que rodea el radio de fábrica. (Figura G)
9. Retire los (4) tornillos Phillips que sostienen el radio. (Figura H)  
*Continúe con el ensamble del kit*

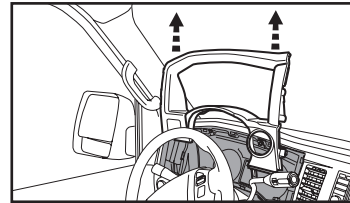

(Figura E)

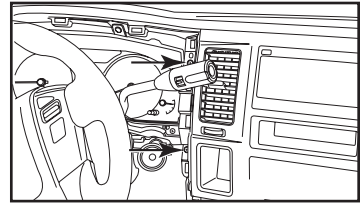

(Figura F)

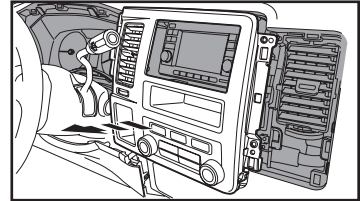

(Figura G)

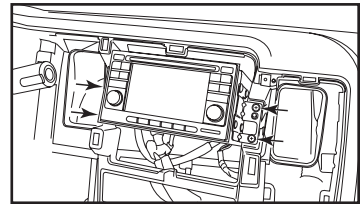

(Figura H)

**Nissan NV200 2013 y mas**

1. Desenganche y quite el botón deslizante de recircular/aire fresco. (Figura A)
2. Desenganche y quite todo el panel de moldura que rodea la pantalla, incluyendo los controles del aire acondicionado. (Figura B)
3. Retire los (4) tornillos Phillips que sostienen el radio. (Figura C)

*Continúe con el ensamble del kit*

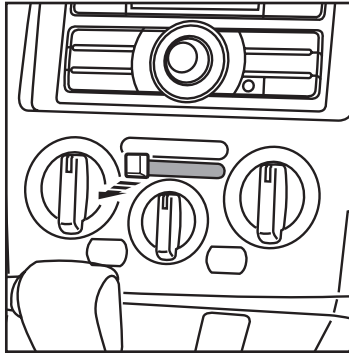

(Figura A)

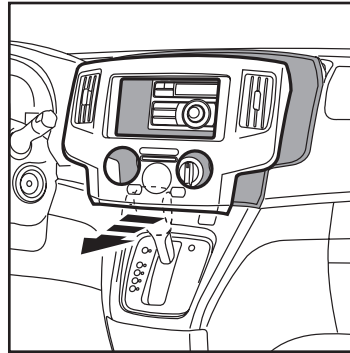

(Figura B)

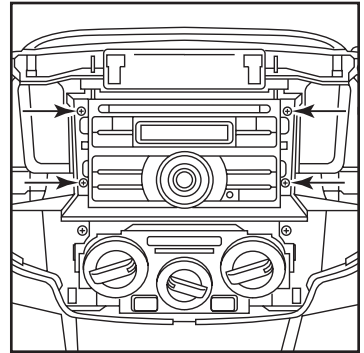

(Figura C)

**Nissan Quest** (sin NAV o entretenimiento para el asiento trasero) **2011 y mas**

1. Desenganche y quite los paneles de la parte izquierda y derecha de abajo de la consola central. (Figura A)
2. Quite los (2) ganchos de cada lado que quedan a la vista detrás de los paneles de abajo. (Figura B)
3. Desenganche y jale la consola central hacia la parte de atrás del vehículo.  
**Nota: No es necesario quitar completamente la consola.** (Figura C)
4. Desenganche y quite el panel de la moldura del lado izquierdo de la palanca de velocidades donde se encuentra el botón de inicio/paro. (Figura D)

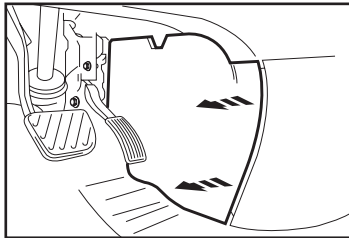

(Figura A)

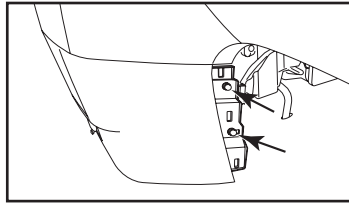

(Figura B)

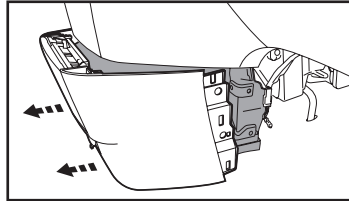

(Figura C)

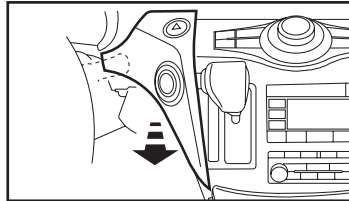

(Figura D)

5. Desenganche y quite el panel que está al final del lado del pasajero en el tablero. (Figura E)
6. Quite (1) tornillo Phillips del panel de la moldura que está arriba de la guantera, luego desenganche y quite el panel. (Figura F)

Continúa en la siguiente página.

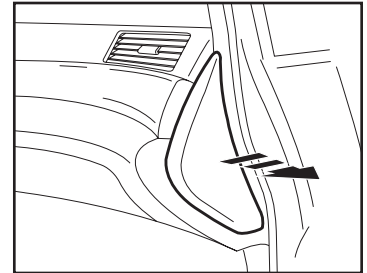

(Figura E)

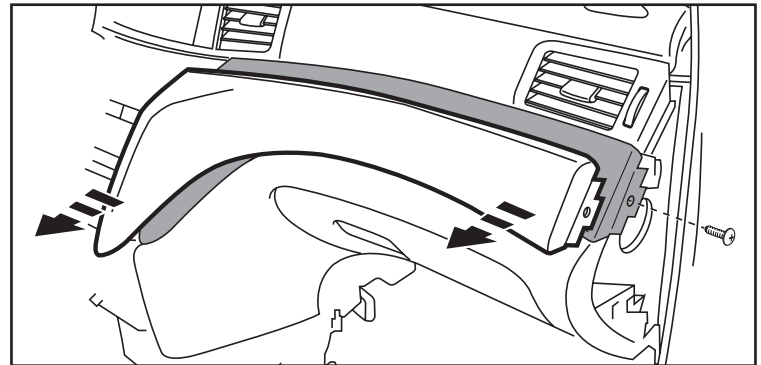

(Figura F)

**Nissan Quest** (sin NAV o entretenimiento para el asiento trasero) **2011 y mas**

7. Quite (1) tornillo Phillips del panel de la moldura del portavasos, luego desenganche y quite el panel. (Figura G)
8. Quite los (2) tornillos Phillips del panel de control del aire acondicionado y desenganche y déjelo colgando. (Figura H)
9. Quite los (2) tornillos Phillips de la parte de abajo del panel de la moldura del radio, incluyendo las rejillas, luego desenganche y quite el panel. (Figura H)
10. Retire los (4) tornillos Phillips que sostienen el radio. (Figura I)  
*Continúe con el ensamble del kit*

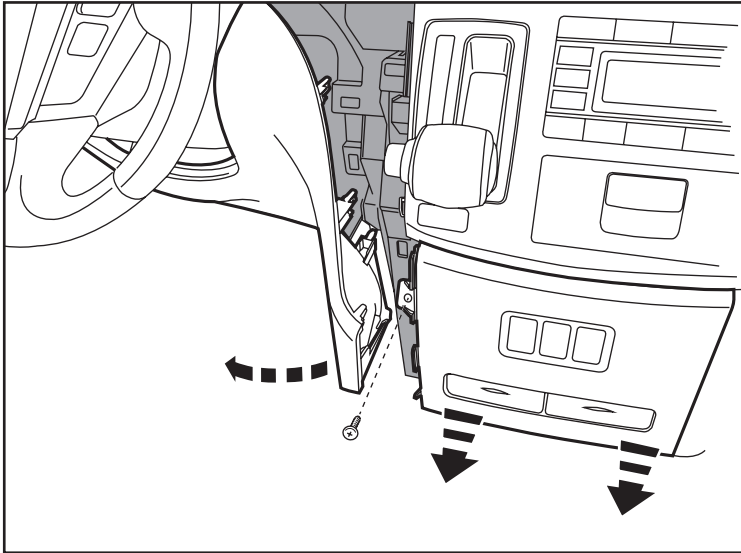

(Figura G)

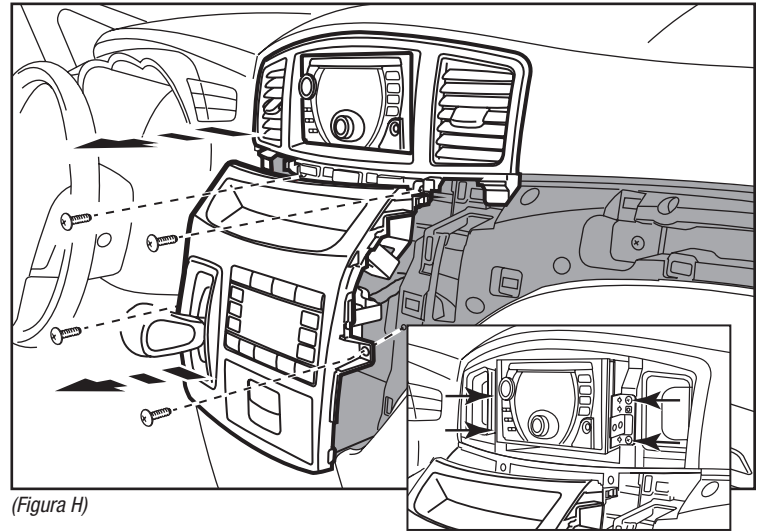

(Figura H)

(Figura I)

**Rogue 2011-2013, Rogue Select 2014**

1. Si está equipado con bocina central: Desenganche y quite la rejilla, luego quite los (4) tornillos Phillips para quitar la bocina. (Figura A)

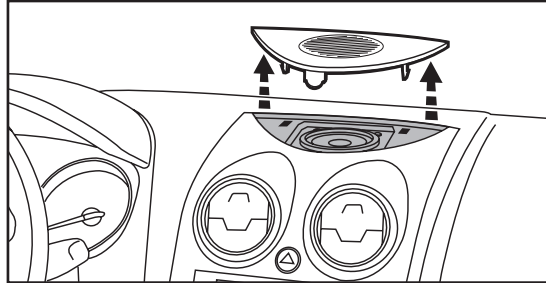

(Figura A)

2. Desenganche y quite el panel de abajo del radio, incluyendo los controles del aire acondicionado. (Figura B)

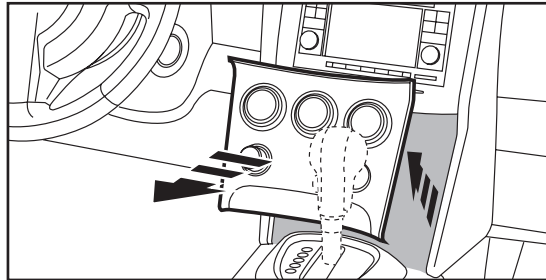

(Figura B)

3. Desenganche la moldura del radio, incluyendo las rejillas del aire acondicionado, luego desconecte el interruptor de las luces intermitentes y quite el panel. (Figura C)

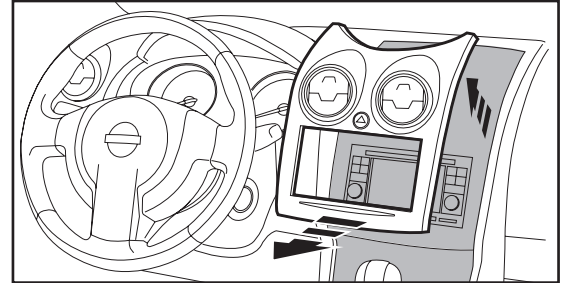

(Figura C)

4. Retire los (4) tornillos Phillips que sostienen el radio. (Figura D)

*Continúe con el ensamble del kit*

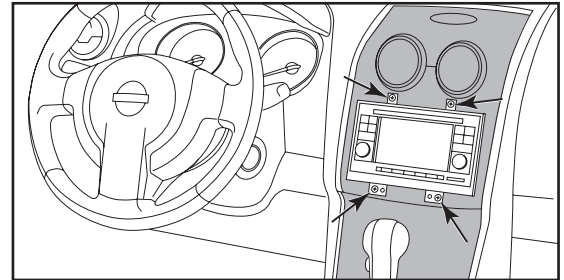

(Figura D)

## Nissan Titan (con pantalla de 4.3") 2013 y mas

1. Desenganche todo el panel del tablero, incluyendo los controles del clima. Desconecte y quite el panel. (Figura A)
2. Retire los (4) tornillos Phillips que sostienen el radio. Desconecte y quite el chasis. (Figura B)

Continúe con el ensamble del kit

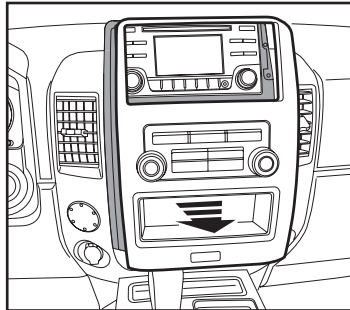

(Figura A)

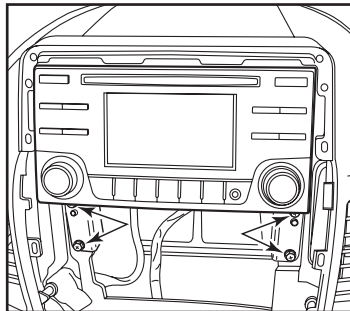

(Figura B)

## Nissan Versa 2007-2011

1. Desenganche y quite el panel de arriba del radio. (Figura A, B)
2. Quite los (2) tornillos Phillips que sostienen el panel de la moldura del radio y luego desenganche y quite todo el panel que rodea el radio y los controles del aire acondicionado. (Figura C)
3. Quite los (4) tornillos Phillips que sostienen el radio, desconecte y quite el radio. (Figura D)

Continúe con el ensamble del kit

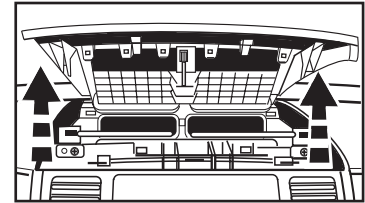

(Figura B)

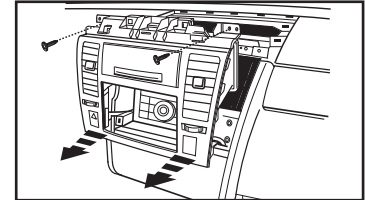

(Figura C)

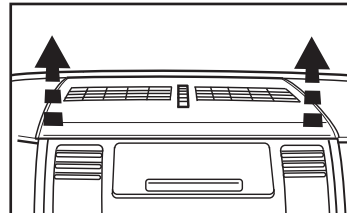

(Figura A)

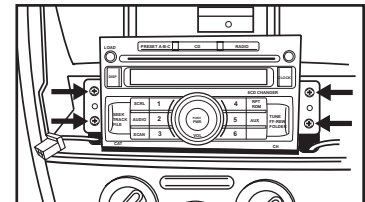

(Figura D)

**Versa 2012 y mas, Versa Note 2014 y mas**

1. Desenganche y quite todo el panel que rodea el radio, incluyendo las rejillas del aire acondicionado. (Figura A)
2. Retire los (4) tornillos Phillips que sostienen el radio. (Figura B)

*Continúe con el ensamble del kit*

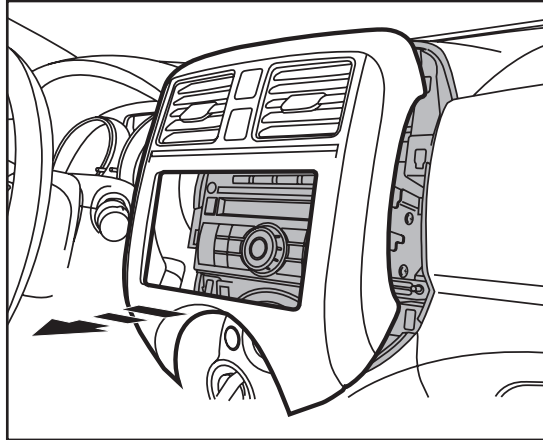

(Figura A)

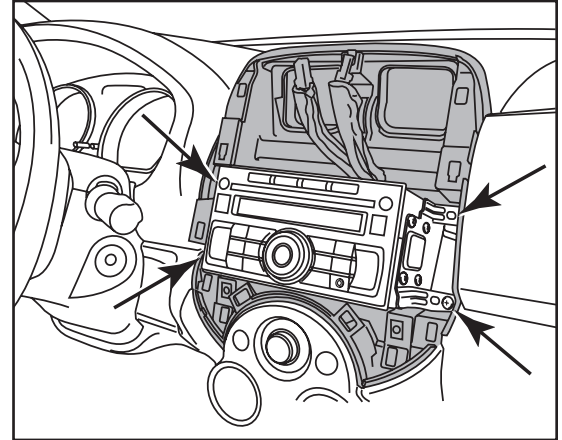

(Figura B)

## Aplicaciones de la placa de la moldura

Vehículo	Panel de moldura
Cube 2009 y mas	Estándar
Frontier (con pantalla de 4.3") 2013 y mas	Ancho
Juke 2011-2014	Estándar
Juke 2015 y mas	Ancho
NV 2012 y mas	Estándar
NV200 2013 y mas, Chevrolet City Express 2015 y mas (sin NAV)	Estándar
NV200 2013 y mas, Chevrolet City Express 2015 y mas (con NAV)	Ancho
Quest (sin NAV o entretenimiento para el asiento trasero) 2011-2012	Estándar
Quest (sin NAV o entretenimiento para el asiento trasero) 2013 y mas	Ancho
Rogue Select (con radio de modelo inferior) 2014	Estándar
Rogue Select (con radio de modelo superior) 2014	Ancho
Rogue S (con Paquete de Edición Especial) 2012-2013	Ancho
Rogue SV 2012-2013	Ancho
Rogue S and SV (con paquete SL) 2003-2007	Estándar
Rogue 2011	Estándar
Titan (con pantalla de 4.3") 2013 y mas	Ancho
Versa 2007-2011	Estándar
Versa 2012-2013	Estándar
Versa S, S+ and SV (sin opciones) 2014	Estándar
Versa Note 2014	Ancho
Versa SL and SV (con Paquete de Conveniencia) 2014	Ancho
Versa and Versa Note (todos los modelos) 2015 y mas	Ancho
Xterra (con pantalla de 4.3") 2013 y mas	Ancho

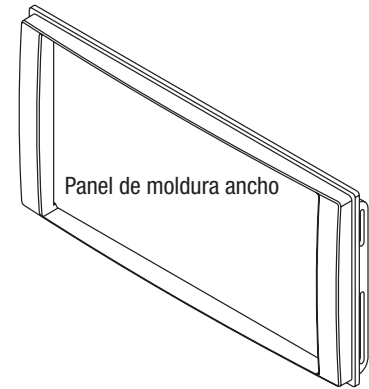
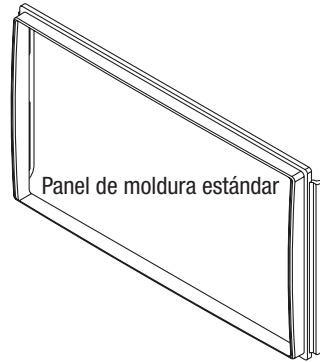



## Disposición de la pestaña del soporte #1

Soporte #	Pestaña	Vehículo	
1	A	Versa	2012 y mas
1	A	Versa Note	2014 y mas
1	B	Rogue	2011-2013
1	B	Rogue Select	2014
1	C	NV	2012 y mas
1	C	Quest (sin NAV o entretenimiento para el asiento trasero)	2011 y mas

**Nota:** Puede ser necesario retirar todas las pestañas no necesarias de los soportes para ciertas aplicaciones. Dependiendo de la aplicación, también puede ser necesario cortar todo el soporte tan cerca como sea posible a los sitios de montaje del radio en los soportes.

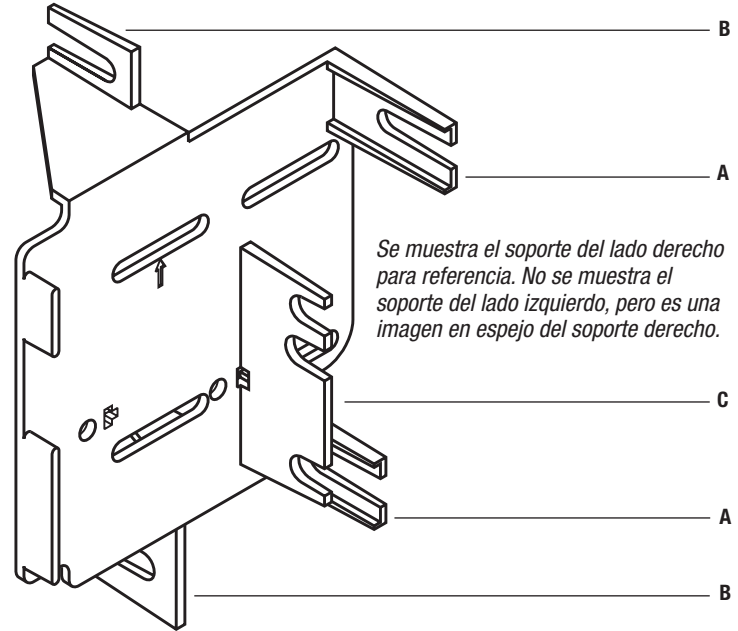

## Disposición de la pestaña del soporte #2

SopORTE #	Pestaña	Vehículo	
2	E	Chevrolet City Express	2015 y mas
2	D	Nissan Juke	2011 y mas
2	E	Nissan NV200	2013 y mas
2	E	Nissan Cube (uso de espaciadores)	2009 y mas

**Nota:** Puede ser necesario retirar todas las pestañas no necesarias de los soportes para ciertas aplicaciones. Dependiendo de la aplicación, también puede ser necesario cortar todo el soporte tan cerca como sea posible a los sitios de montaje del radio en los soportes.

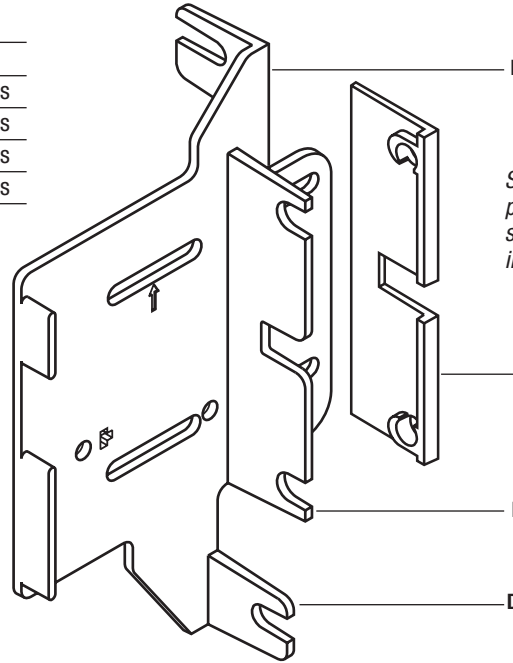

*Se muestra el soporte del lado derecho para referencia. No se muestra el soporte del lado izquierdo, pero es una imagen en espejo del soporte derecho.*

— Espaciador para Nissan Cube, úselo con el juego de soportes 2, pestaña E

## Disposición de la pestaña del soporte #3

Soporte #	Pestaña	Vehículo
3	F	Frontier/Xterra (con pantalla de 4.3") 2013 y mas
3	G	Titan 2013 y mas
3	H	Versa 2007-2011

**Nota:** Puede ser necesario retirar todas las pestañas no necesarias de los soportes para ciertas aplicaciones. Dependiendo de la aplicación, también puede ser necesario cortar todo el soporte tan cerca como sea posible a los sitios de montaje del radio en los soportes.

1. Corte y quite el área sombreada de los soportes para Frontier y Xterra 2013 y más recientes. (Figura A)
2. Corte y quite el área sombreada de los soportes para la Titan 2013 y más recientes. (Figura A)

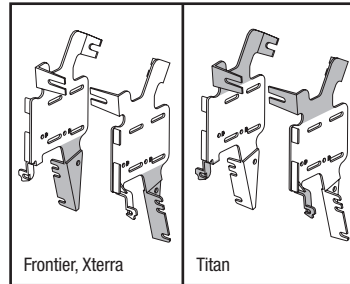

(Figura A)

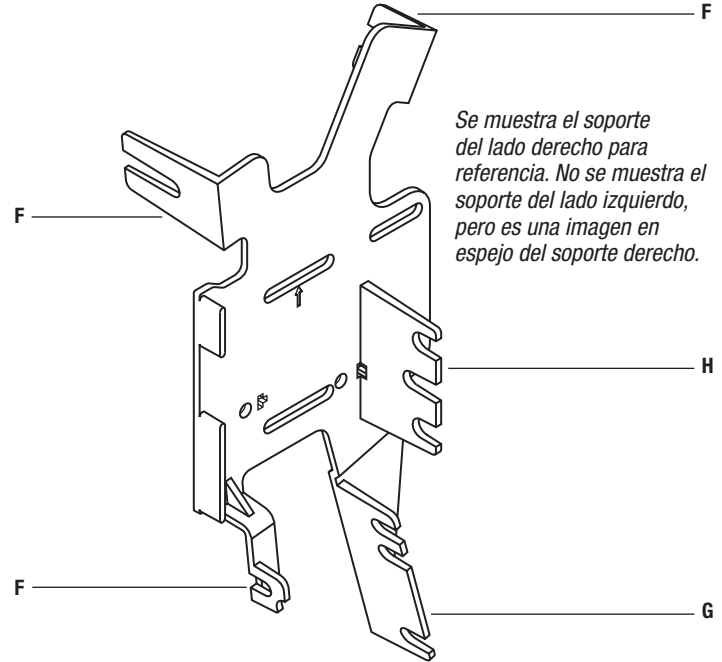

Se muestra el soporte del lado derecho para referencia. No se muestra el soporte del lado izquierdo, pero es una imagen en espejo del soporte derecho.

## Ensamble del kit

### Provisión de radio DDIN

1. Una el soporte correspondiente al panel de la moldura de la carcasa del radio. *(Se muestra el soporte #2 con el panel de la moldura del radio estándar)* (Figura A)
2. Deslice el radio en el conjunto del soporte y sujételo con los tornillos suministrados con el radio. (Figura B)
3. Ubique el arnés de cableado de fábrica y el conector de la antena en el tablero. Metra recomienda el uso de los adaptadores adecuados de acoplamiento de Metra y/o AXXESS.
4. Monte el conjunto del radio en el tablero y vuelva a armar el tablero al revés de como lo desarmó.

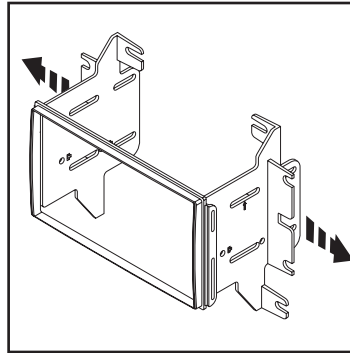

(Figura A)

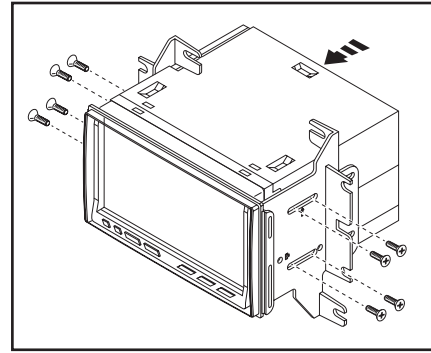

(Figura B)









## INSTRUCCIONES DE INSTALACIÓN PARA LA PIEZA 95-7624



REV 1/2015 INST95-7624



### EL CONOCIMIENTO ES PODER

Mejora sus habilidades de instalación y fabricación inscribiéndose en la escuela de dispositivos electrónicos móviles más reconocida y respetada de nuestra industria. Regístrese en [www.installerinstitute.com](http://www.installerinstitute.com) o llame al 800-354-6782 para obtener más información y avance hacia un futuro mejor.



**Metra recomienda técnicos con certificación del Programa de Certificación en Electrónica Móvil (Mobile Electronics Certification Program, MECP).**